



Bishamon BS Series Blue Label Pallet Trucks are easy to use and exceptionally durable. They are designed and manufactured to easily move palletized loads. By utilizing top quality components and advanced manufacturing techniques, Bishamon's BS Series pallet trucks can be expected to outlast competitive models that promise comparable quality. Blue Label Pallet Trucks are found in warehouses, factories, stockrooms, super markets, workshops, cold-rooms and freezers. They may also be used on loading docks and inside trucks.

**Outstanding Durability:** Adopted "High Tensile Steel" which is both very light and strong for main body frame to enhance the durability.

**High Durable Cylinder:** Top quality **proprietary piston cylinder** is designed for frequent use and also the **U-packing** on seal makes it hard to generate oil leakage.

**Smooth Maneuverability:** 2 pieces of **Thrust Bearing** on handle axle and **proprietary Polyurethane Wheels** make the manoeuvrability ultimately light and easy.

### Standard Features

- Ergonomic three position hand lever controls lift, lower and neutral functions with the handle in any position
- Handle swivels through 210 degrees
- Steering head and hydraulic assembly use quality, low-friction thrust bearings
- High quality polyurethane wheels and load rollers provide superior rollability and durability
- Premium quality ball bearings in all wheels and load rollers
- Rugged construction, with high strength steel and continuous welds
- One piece formed forks add strength and durability
- Additional fork reinforcement plate provides extra strength to keep forks parallel
- Durable formed steel entry slide guides truck into pallets and diverts debris
- Solid steel, non-adjustable push rods increase durability
- Hydraulic assembly and frame are completely rebuildable
- Quality baked enamel finish

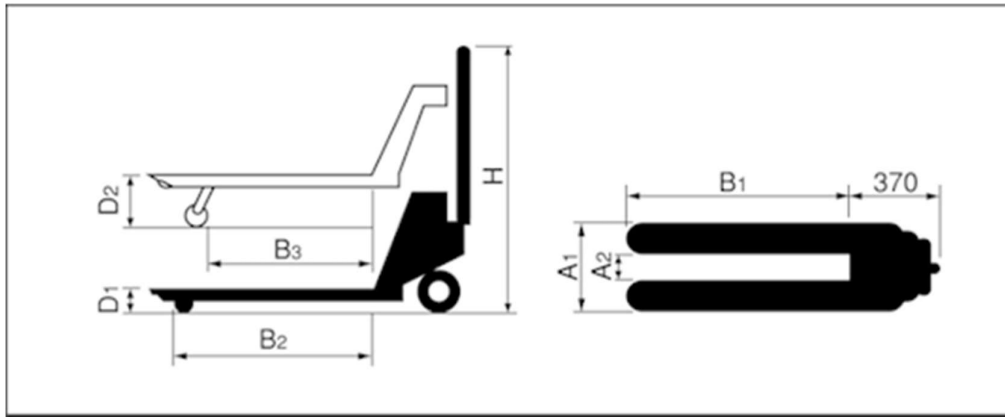

### Standard Model

Model	Capacity kg	Fork Dimensions							Weight kg
		A1 mm	B1 mm	D1 mm	D2 mm	A2 mm	B2 mm	B3 mm	
BM25M	2,500	520	1,070	80	200	214	935	785	89
BM25L	2,500	520	1,150	80	200	214	1,015	865	92
BM25LL	2,500	685	1,220	80	200	379	1,085	935	99



### Hand Lever Control

Three-Position Control Lever Provides Fingertip Control Of All Hydraulic System Functions With The Handle In Any Position



### Debris Diversion

Formed Steel Entry Slide Diverts Debris And Guides Pallet Truck Into Pallet



### Strength and Durability

Formed Fork For Added Strength And Durability



### Hydraulic System

Self-Contained Rebuildable Hydraulic System