



Application

- Can be used to transfer clean water or other liquids similar to water in physical and chemical properties
- Suitable for industrial use and urban water supply, pressure boosting for high buildings and fire fighting, garden irrigation, long-distance water transfer, heating ventilation and air controlling, circulation and pressure boosting for cold and hot water, and supporting equipment etc.

Pump

- Cast iron pump body and support under special anti-rust treatment
- AISI 304 shaft
- Max. liquid temperature: +40°C
- Max. suction: +8 m

Motor

- C&U bearing
- Motor with copper winding
- Insulation class: F
- Protection class: IPX4
- Max. ambient temperature: +40°C

Identification Codes

A C m 220 C (H) 2

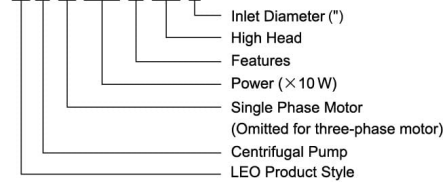

Technical Data

MODEL		POWER		Q (m³/h)												
Single Phase	Three Phase	kW	HP	0	6	9	12	15	18	24	27	30	36	42	48	54
ACm220CH2	AC220CH2	2.2	3	31	30	29.5	28.5	27.5	26	21.5	18.5	-	-	-	-	-
ACm300CH2	AC300CH2	3	4	38	37.5	37	36	34.5	33	28.5	25.5	-	-	-	-	-
ACm400CH2	AC400CH2	4	5.5	49	48	47	46	45	43.5	39.5	37	-	-	-	-	-
---	AC550CH2	5.5	7.5	54	52.5	52	51	50	49	46	44	42	-	-	-	-
ACm300C2	AC300C2	3	4	30	29.5	29	28.5	28	27	25	23.5	22	19.5	15.5	11.5	-
ACm400C2	AC400C2	4	5	39	38.5	38	37.5	37	36	34	32.5	31	28	24	18.5	13
---	AC550C2	5.5	7.5	46.5	45.5	45	44.5	43.5	42.5	40	38.5	37	33	28	22	15
---	AC750C2	7.5	10	56.5	55	55	54.5	53.5	52.5	50	48.5	46.5	42	36.5	30.5	20
---	AC750C4	7.5	10	52.5	52	52	51.5	51	50.5	48	46.5	44.5	40	35.5	30.5	24

Dimension

Model	DN1	DN2	L (mm)	W (mm)	H (mm)	L ₁ (mm)	W ₁ (mm)	H ₁ (mm)
ACm220CH2	2"	2"	444	255	315	65	186	132
ACm300CH2			444	255	315	65	186	132
ACm400CH2			496.5	280	326	70	195	136
AC550CH2			496.5	280	326	70	195	136
ACm300C2			444	255	315	65	186	132
ACm400C2			496.5	280	326	70	195	136
AC550C2			496.5	280	326	70	195	136
AC750C2			515	290	360	85	216	150
AC750C4			525	290	360	95	216	150

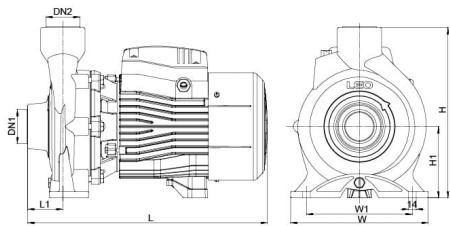

Hydraulic Performance Curves

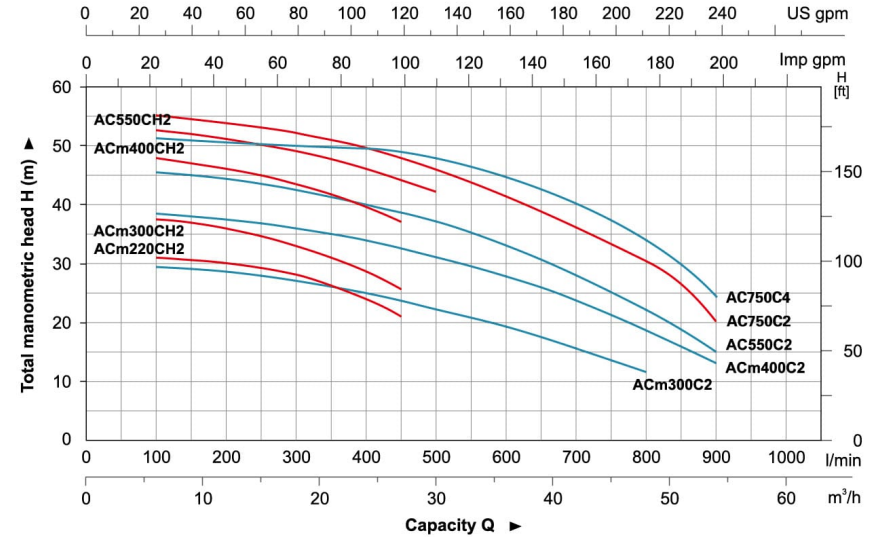

Materials Table

No.	Part	Material
1	Pump body	HT200
2	Impeller	AISI 304 Brass
3	Mechanical seal	Carbon/Ceramic
4	Bracket cover	HT200
5	Oil seal	
6	Support	HT200
7	Bearing	
8	Rotor	
9	Fan cover	PP
10	Fan	PP
11	Rear cover	ZL102
12	Stator	
13	Capacitor	
14	Terminal box	ABS

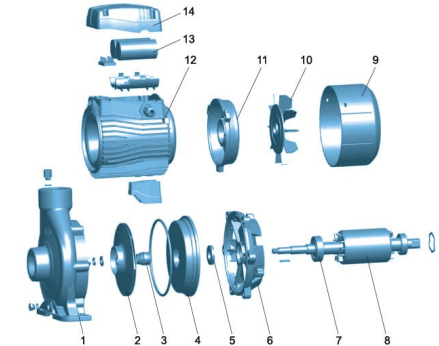

Package Information

Model	GW (Kgs)	L (mm)	W (mm)	H (mm)	Quantity (PCS/20 TEU)
ACm220CH2	39	507	304	372	486
ACm300CH2	41.8	507	304	372	478
ACm400CH2	56.5	562	328	383	345
AC550CH2	57.1	562	328	383	345
ACm300C2	41.4	507	304	372	483
ACm400C2	57.5	562	328	372	345
AC550C2	55.5	562	328	383	345
AC750C2	62	587	338	417	305
AC750C4	63.7	587	338	417	305

